

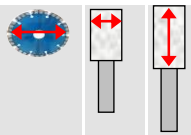









nazwa, opis	odtworzenie				cena cennikowa netto							dla typu maszyn
		średnica mm	szerokość segmentu mm	wysokość segmentu incl. appr. 2mm neutral zone mm		Beton	Asfalt, materiały abrazyjne	Kamien naturalny	Ceramika	Metale	klinkier twarde	
					B	A	N	KR	M	KL	KS	

**BETON**

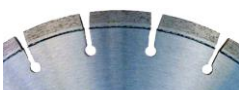
<p><b>CD 3014</b> Betón, produkty betonowe, mur ceglany Właściwy dla lżejszej pracy Nie ciąć świeżego betonu (do 28 dni)!</p>	 Segment: sinter, 10mm ★★	115	2,4	10	17,33	B							
		125	2,4	10	20,79	B							
		150	2,4	10	31,19	B							
		180	2,8	10	45,05	B							
		230	3,0	10	62,37	B							
<p><b>CD 3645 BLOCK-TURBO</b> Betón, betonové výrobky, železobeton, žulový obrubník, střešní krytina, pálená cihla, slínek, velmi univerzální dobrý vztah cena/práce, dlouho životnosti, velmi silný</p>	 Segment: Laser, 10mm ★★★	115	2,4	10	34,65	B	N						
		125	2,4	10	48,51	B	N						
		150	2,4	10	58,91	B	N						
		180	2,8	10	72,77	B	N						
		230	3,0	10	142,07	B	N						
		300	3,2	10	277,20	B	N						
		350	3,2	10	339,57	B	N						
<p><b>CD 2135 LASER-BETON</b> Betón, produkty betonowe, betón zbrojony, mur ceglany, pol-bruk, krawężniki Narzędzie za ekonomiczną cenę Nie ciąć świeżego betonu (do 28 dni)!</p>	 Segment: Laser, 10mm ★★★★	115	2,2	10	69,30	B	N						
		125	2,2	10	76,23	B	N						
		150	2,6	10	86,63	B	N						
		230	2,6	10	110,88	B	N						
		300	3,0	10	194,04	B	N						
		350	3,2	10	249,48	B	N						
		400	4,0	10	363,83	B	N						
		450	3,6	10	450,45	B	N						
<p><b>CD 2145 LASER-BETON</b> Betón, produkty betonowe, betón zbrojony, mur ceglany, pol-bruk, krawężniki granitowe Bardzo silne narzędzie profesjonalne dla bardzo ciężkiej pracy Nie ciąć świeżego betonu (do 28 dni)!</p>	 Segment: Laser, 10/12mm ★★★★★	230	2,6	12	214,83	B	N						
		300	3,0	12	311,85	B	N						
		350	3,2	12	398,48	B	N						
		400	3,5	12	467,78	B	N						
		450	4,0	12	623,70	B	N						
		500	4,5	10	744,98	B	N						
		600	4,5	12	1074,15	B	N						
		650	4,5	12	1230,08	B	N						
		700	4,5	12	1472,63	B	N						
<p><b>CD 2110-10 SE LASER BETON</b> Betón, produkty betonowe, betón zbrojony, krawężniki Bardzo silne narzędzie Profesjonalne dla bardzo ciężkiej pracy, ekstremalnie długa żywotność <b>PREMIUM PLUS</b> Nie ciąć świeżego betonu (do 28 dni)!</p>	 Segment: Laser, 10mm ★★★★★	300	2,8	10	450,45	B	N						
		350	2,8	10	533,61	B	N						
		400	3,2	10	706,86	B	N						
		450	3,4	10	866,25	B	N						
		500	3,4	10	990,99	B	N						
		600	3,5	10	1434,51	B	N						

**dalszy ciąg BETON**

**CD 24112 BETON ARXX**

**Stary beton, beton zbrojony**  
 najwyższa jakość  
 narzędzie profesjonalne,  
**ekstremalnie długa**  
**żywytność przez,**  
**ARXX-technologie segmentów,**

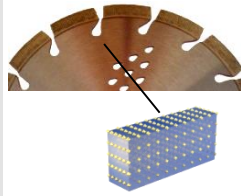

ARXXSegment Laser, 12mm  
 ★ ★ ★ ★ ★

115	2,4	12	176,72	B				
125	2,4	12	190,58	B				
150	2,4	12	235,62	B				
178	2,4	12	277,20	B				
230	2,4	12	304,92	B				
300	3,0	12	481,64	B				
350	3,2	12	585,59	B				
400	3,5	12	762,30	B				
450	4,0	12	900,90	B				
500	4,0	12	1212,75	B				
600	4,2	12	1836,45	B				
700	4,2	12	2390,85	B				



cięcia na sucho i mokro



**CD 2118 ROXX**

**Beton, Beton armiert, Ziegel, Granitborde, Mauerwerk, universal,**  
 Spezial-Trapezsegment **17mm,**  
 sehr hohe Standzeit, ein  
 Premium-Werkzeug in Beton

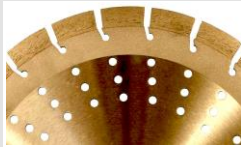

Segment gelasert, 17mm  
 ★ ★ ★ ★ ★

115	2,3	17	145,53	B	N	KL		
125	2,3	17	159,39	B	N	KL		
150	2,6	17	197,51	B	N	KL		
178	2,6	17	235,62	B	N	KL		
230	2,8	17	339,57	B	N	KL		
300	3,0	17	516,29	B	N	KL		
350	3,2	17	686,07	B	N	KL		
400	3,5	17	862,79	B	N	KL		

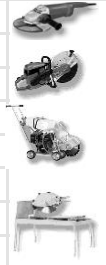

**BETON, segment TURBO**

**CD 21735 (ex 21711)**

**Beton, produkty betonowe, beton zbrojony, mur ceglany, dachówka, pol-bruk, krawężniki granitowe**  
 Dobra jakość przy niskiej cenie

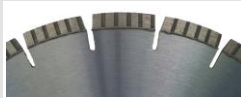

Segment: Laser, 10mm  
 ★ ★ ★

115	2,3	10	55,44	B	N			
125	2,3	10	62,37	B	N			
150	2,6	10	79,70	B	N			
180	2,6	10	97,02	B	N			
230	2,6	10	114,35	B	N			
300	3,0	10	200,97	B	N			
350	3,2	10	249,48	B	N			

cięcia na sucho i mokro



**CD 2175 LASER-TURBO**

**Beton, produkty betonowe, beton zbrojony, mur ceglany, dachówka, pol-bruk, krawężniki granitowe**  
 Szybkie cięcia przy dobrej żywytność,  
 niezawodny i wszechstronny  
 z doskonałym połączeniem ceny i jakości



Segment gelasert, 12mm  
 Abm. 200, 250 10mm  
 ★ ★ ★ ★ ★

115	2,3	12	93,56	B	N			
125	2,3	12	100,49	B	N			
135x30 4NL			131,67	B	N	für FUBAG		
140	2,4	12	149,00	B	N			
150	2,6	12	131,67	B	N			
180	2,6	12	155,93	B	N			
200	2,6	10	187,11	B	N			
230	2,6	12	214,83	B	N			
250	2,6	10	225,23	B	N			
300	3,0	12	329,18	B	N			
350	3,2	12	363,83	B	N			
380	3,2	12	450,45	B	N			
400	3,5	12	485,10	B	N			
450	4,0	12	641,03	B	N			
500	4,0	12	824,67	B	N			
600	4,5	12	1004,85	B	N			
650	4,5	12	1230,08	B	N			
700	4,5	12	1472,63	B	N			
800	4,5	12	1940,40	B	N			

cięcia na sucho i mokro



**CD 2187 TURBO-LASER-STANDARD**

**Beton, beton zbrojony, produkty betonowe, pol-bruk, krawężniki granitowe itd.**

Ekskluzywny i wszechstronny z doskonałym  
 połączeniem ceny i jakości,  
 długa żywytność

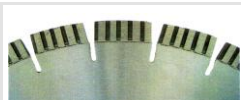

Segment: Laser, 15mm  
 Segment: Laser, 15mm  
 ★ ★ ★ ★ ★

230	2,6	15	228,69	B	N			
300	3,0	15	318,78	B	N			
350	3,2	15	374,22	B	N			

cięcia na sucho i mokro





**BETON , EKSTRA SZEROKOŚĆ SEGMENTU****CD 1106 BETON****Beton (stary)**

Specjalna narzędzie  
do szerszego cięcia,  
ekstra szerokość segment



Segment. lutowane, 6mm

★★★★★

300	6,0	6	921,69	B					
300	8,0	6	1008,32	B					
300	10,0	6	1188,50	B					
300	12,0	6	1365,21	B					
300	15,0	6	1638,95	B					
350	6,0	6	1074,15	B					
350	8,0	6	1167,71	B					
350	10,0	6	1382,54	B					
350	12,0	6	1586,97	B					
350	15,0	6	1905,75	B					

cięcie na mokro

**ASFALT, MATERIAŁY ABRAZYJNE****CD 31090 SUPER-ABRASIV**

**Jastrich, asfalt, piaskowiec,  
beton abrazyjne i świeży,  
poroton, materiały abrazyjne**

Ekstremalnie długa żywotność

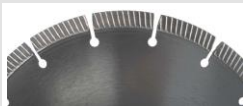
**PREMIUM**

Segment: sinter, 10mm

★★★★★

115	2,0	10	117,81	A					
125	2,0	10	145,53	A					
150	2,0	10	221,76	A					
180	2,2	10	249,48	A					
230	2,5	10	277,20	A					

cięcie na sucho i mokro

**CD 20011 LASER-ASPHALT**

**Asfalt, jastrich,  
materiały abrazyjne**

z tarczą ochronną segmentu



Segment: Laser, 10mm

★★★

300	2,8	10	249,48	A					
350	3,2	10	318,78	A					
400	3,5	10	381,15	A					
450	4,2	10	502,43	A					
500	4,5	10	623,70	A					
600	4,5	10	952,88	A					

cięcie na sucho i mokro

**CD 2001 LASER-ASPHALT**

**Asfalt, jastrich,  
materiały abrazyjne**

Z tarczą ochronną segmentu,  
bardzo silne narzędzie profesjonalne  
dla ciężkiej pracy



Segment: Laser, 10mm

★★★★★

300	3,0	10	311,85	A					
350	3,2	10	398,48	A					
400	3,5	10	467,78	A					
450	4,2	10	623,70	A					
500	4,5	10	744,98	A					
600	4,5	10	1074,15	A					
650	4,5	10	1455,30	A					
700	4,5	10	1697,85	A					

cięcie na sucho i mokro

**CD 2015-15 LASER-ASPHALT**

**Asfalt, jastrich,  
materiały abrazyjne**

Z tarczą ochronną segmentu,  
bardzo silne narzędzie profesjonalne  
dla ciężkiej pracy,  
**15mm-segment!**



Segment: Laser, 15mm

★★★★★

300	3,0	15	398,48	A					
350	3,2	15	533,61	A					
400	3,5	15	665,28	A					
450	4,2	15	932,09	A					
500	4,5	15	1081,08	A					
600	4,5	15	1545,39	A					

cięcie na sucho i mokro

**CD 2010 SE LASER-ASPHALT**

**Asfalt, jastrich,  
materiały abrazyjne**

Z tarczą ochronną segmentu,  
bardzo silne narzędzie profesjonalne,  
ekstremalnie długa żywotność

**PREMIUM**

Segment: Laser, 10mm

★★★★★









300	2,8	10	540,54	A					
350	3,2	10	641,03	A					
400	3,2	10	814,28	A					
450	3,4	10	1036,04	A					
500	3,4	10	1084,55	A					
600	4,0	10	1652,81	A					











cięcie na sucho i mokro





**... ASFALT, MATERIAŁY ABRAZYJNE**









<b>CD 1001 ASPHALT</b>																							
<b>Asfalt, jastrich, materiały abrazyjne</b> Z tarczą ochronną segmentu, bardzo silne narzędzie profesjonalne dla przecinarek drogowych <b>PREMIUM</b>		<b>350</b>	3,2	<b>8</b>	862,79	A																	
		<b>400</b>	4,0	<b>8</b>	1018,71	A																	
		<b>450</b>	3,6	<b>8</b>	1257,80	A																	
		<b>500</b>	4,0	<b>8</b>	1399,86	A																	
		<b>600</b>	4,5	<b>8</b>	1850,31	A																	
		<b>700</b>	4,5	<b>10</b>	2636,87	A																	
	<b>800</b>	4,5	<b>10</b>	3170,48																			
																						cięcie na mokro	







<b>CD 1006 ASPHALT EXTRA WIDE</b>																							
<b>Asfalt</b> Specjalna narzędzie do szerszego cięcia, ekstra szerokość segment		<b>300</b>	6,0	<b>6</b>	1008,32	A																	
		<b>300</b>	8,0	<b>6</b>	1167,71	A																	
		<b>300</b>	10,0	<b>6</b>	1327,10	A																	
		<b>300</b>	12,0	<b>6</b>	1586,97	A																	
		<b>350</b>	6,0	<b>6</b>	1167,71	A																	
		<b>350</b>	8,0	<b>6</b>	1354,82	A																	
		<b>350</b>	10,0	<b>6</b>	1541,93	A																	
		<b>350</b>	12,0	<b>6</b>	1843,38	A																	
		<b>350</b>	15,0	<b>6</b>	2127,51	A																	
																						cięcie na mokro	

**bardzo ŚWIEŻY BETON**

<b>CD 1202-E FRISCHBETON</b>																								
<b>Narzędzie specjalne dla bardzo świeży beton</b> Z tarczą ochronną segmentu <b>PREMIUM-PLUS</b>		<b>350</b>	3,2	<b>10</b>	1108,80																			
		<b>400</b>	3,2	<b>10</b>	1316,70																			
		<b>450</b>	3,4	<b>10</b>	2079,00																			
																							cięcie na mokro	

**GRANIT, MATERIAŁOW TWARDYCH**

<b>CD 36041</b>																							
<b>Granit, klinkier, cegła, rury kamienne (kamionka), beton, beton zbrojony, dachówka ceramiczna, kamień naturalny twarde i sztuczne</b> Bardzo szybkie cięcie		<b>115</b>	2,1	<b>8</b>	58,91	B	N																
		<b>125</b>	2,2	<b>8</b>	69,30	B	N																
		<b>150</b>	2,2	<b>8</b>	100,49	B	N																
		<b>180</b>	2,4	<b>8</b>	128,21	B	N																
		<b>230</b>	2,4	<b>8</b>	200,97	B	N																
		<b>300</b>	2,8	<b>10</b>	401,94	B	N																
		<b>350</b>	3,0	<b>10</b>	498,96	B	N																
																						cięcie na sucho i mokro	

<b>CD 23006</b>																							
<b>Granit, klinkier, cegła, beton, beton zbrojony, rury żeliwne, rury kamienne, dachówka ceramiczna, kamień naturalny twarde i sztuczne</b> szybkie i czyste cięcie, długa żywotność dla wszystkich twardych materiałów		<b>115</b>	2,0	<b>12</b>	93,56	B	N	KL															
		<b>125</b>	2,2	<b>12</b>	110,88	B	N	KL															
		<b>230</b>	2,8	<b>12</b>	263,34	B	N	KL															
		<b>300</b>	3,0	<b>12</b>	436,59	B	N	KL															
		<b>350</b>	3,2	<b>12</b>	516,29	B	N	KL															
																							Naß + Trockenschnitt



















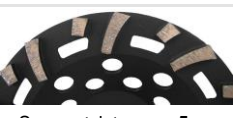

<b>CD 26050 SUPER-SPEED-CUT</b>																							
<b>Granit, klinkier, cegła, beton, beton zbrojony, rury żeliwne, rury kamienne, dachówka ceramiczna, kamień naturalny twarde i sztuczne</b> Z tarczą ochronną segmentu, bardzo szybkie cięcie, narzędzie najwyższej jakości idealne do materiałów twardych		<b>115</b>	2,2	<b>9</b>	103,95	B	N	M															
		<b>125</b>	2,2	<b>9</b>	110,88	B	N	M															
		<b>150</b>	2,2	<b>9</b>	138,60	B	N	M															
		<b>180</b>	2,4	<b>9</b>	176,72	B	N	M															
		<b>230</b>	2,8	<b>9</b>	266,81	B	N	M															
		<b>300</b>	3,2	<b>9</b>	502,43	B	N	M															
		<b>350</b>	3,4	<b>9</b>	606,38	B	N	M															
																						cięcie na sucho i mokro	

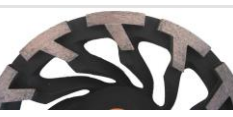
<b>CD 42088 HARTBRANDKLINKER</b>																							
<b>Granit, klinkier twarde, kamień nat. twarde i sztuczne</b> Ekstremalnie szybkie cięcie, <b>"SANDWICH"</b>		<b>350</b>	2,8	<b>10</b>	814,28		N	KL															
																							cięcie na mokro





## SZLIFIERKA DIAMENTOWA

<b>CD 2909</b> <b>Beton, kamień naturalny, twarde materiały</b>	 Segment: lutowane, 5mm ★★★	<b>125</b>	<b>5</b>	<b>155,93</b>	B	N		
<b>CD 2904 DOPPELT</b> <b>Beton, kamień naturalny, jastrich, uniwersalny</b> Dwurzędowy, bardzo uniwersalny, doskonałe połączenie ceny i jakości	 Segment: lutowane, 5mm ★★★	<b>100</b> <b>110</b> <b>125</b> <b>150</b> <b>180</b>	<b>5</b> <b>5</b> <b>5</b> <b>5</b> <b>5</b>	<b>149,00</b> <b>169,79</b> <b>190,58</b> <b>308,39</b> <b>343,04</b>	B B B B B	N N N N N		
<b>CD 2924 ABRASIV (schwarz)</b> <b>Asfalt, jastrich, piaskowiec, materiały abrazyjne</b> Dwurzędowy, doskonałe połączenie ceny i jakości	 Segment: lutowane, 5mm ★★★	<b>100</b> <b>110</b> <b>125</b> <b>180</b> <b>230</b>	<b>5</b> <b>5</b> <b>5</b> <b>5</b> <b>5</b>	<b>194,04</b> <b>211,37</b> <b>228,69</b> <b>388,08</b> <b>727,65</b>	A A A A A			
<b>CD 2916 BETON CUP special</b> <b>Beton, kamień naturalny itd., żywica epoksydowa, kolorowe warstwy</b> Idealnie do Bosch/Eibenstock	 Segment: lutowane, 5mm ★★★	<b>100</b> <b>115</b> <b>125</b> <b>180</b>	<b>5</b> <b>5</b> <b>5</b> <b>5</b>	<b>207,90</b> <b>228,69</b> <b>259,88</b> <b>419,27</b>	B B B B			
<b>CD 2917 ABRASIV CUP special</b> <b>Asfalt, jastrich, mat.abrazyjne żywica epoksydowa, kolorowe warstwy</b> Idealnie do Bosch/Eibenstock	 Segment: lutowane, 5mm ★★★	<b>100</b> <b>115</b> <b>125</b> <b>180</b>	<b>5</b> <b>5</b> <b>5</b> <b>5</b>	<b>207,90</b> <b>228,69</b> <b>259,88</b> <b>419,27</b>	A A A A			
<b>CD 2914 BETON T- CUP</b> <b>Beton, kamień naturalny, twarde materiały</b> Korpus "TURBINY" dla efektywnego odpylania, idealnie do Bosch/Eibenstock	 Segment: lutowane, 5mm ★★★	<b>100</b> <b>115</b> <b>125</b> <b>150</b> <b>180</b>	<b>5</b> <b>5</b> <b>5</b> <b>5</b> <b>5</b>	<b>207,90</b> <b>228,69</b> <b>259,88</b> <b>363,83</b> <b>419,27</b>	B B B B B	N N N N N		
<b>CD 2915 ABRASIV T-CUP</b> <b>Asfalt, jastrich, piaskowiec, materiały abrazyjne</b> Korpus "TURBINY" dla efektywnego odpylania, idealnie do Bosch/Eibenstock	 Segment: lutowane, 5mm ★★★	<b>100</b> <b>115</b> <b>125</b> <b>150</b> <b>180</b>	<b>5</b> <b>5</b> <b>5</b> <b>5</b> <b>5</b>	<b>207,90</b> <b>228,69</b> <b>259,88</b> <b>363,83</b> <b>419,27</b>	A A A A A			
<b>CD 29050 TURBO</b> <b>Granit, beton, kamień naturalny, twarde materiały</b> segmenty typu „TURBO”	  wysokość segmentu: 6mm ★★★	<b>50 M14</b> <b>80 M14</b> <b>100</b> <b>100 M14</b> <b>110</b> <b>110 M14</b> <b>125</b> <b>125</b> <b>125</b> <b>125 M14</b> <b>178</b> <b>178</b> <b>178</b>	Höhe: 22 Höhe: 33 Höhe: 21 Höhe: 33 Höhe: 22 Höhe: 22 Höhe: 22 Höhe: 33 Höhe: 22 Höhe: 22 Höhe: 22	<b>214,83</b> <b>256,41</b> <b>259,88</b> <b>259,88</b> <b>308,39</b> <b>308,39</b> <b>363,83</b> <b>363,83</b> <b>363,83</b> <b>363,83</b> <b>502,43</b> <b>502,43</b> <b>502,43</b>	B B B B B B B B B B B B B	N N N N N N N N N N N N N N	<b>K30/40 grob</b> <b>K30/40 grob</b> <b>K30/40 grob</b> <b>K30/40 grob</b> <b>K30/40 grob</b> <b>K30/40 grob</b> <b>K60/70 medium</b> <b>K100/120 fein</b> <b>K30/40 grob</b> <b>K30/40 grob</b> <b>K60/70 medium</b> <b>K30/40 grob</b> <b>K100/120 fein</b>	 
<b>CD 29079-1-B</b> <b>Granit, beton, kamień naturalny, segmenty typu „TURBO”</b> <b>korpus aluminium, M14</b>	 wysokość segmentu: 6mm ★★★	<b>100</b>	grubo <b>6</b>	<b>173,25</b>	B	N		





**DIAMENTOWE WIERTŁA KORONOWE GRES, CERAMIKA**

**CD 55700**

**Gres, płytki ceramiki, glazura ceramiki, kafel, twarda ceramika, kamionka, płytki kamienne, terakotta, plastik, szkło**

Bardzo szybkie, czyste i dokładne wiercenie, ekstra cienkościenny, proste swobodne wiercenie, doskonale połączenie ceny/jakości, łatwe chłodzenie z areozolem/butelką ze sprejem, dla wiertarek i wiertarko-wkrętarek akumulatorowych, **mocowanie: 6-kanciasty**



6	41,58	N	KR
8	45,05	N	KR
10	51,98	N	KR
12	58,91	N	KR
14	65,84	N	KR
16	72,77	N	KR
18	79,70	N	KR
20	83,16	N	KR
22	86,63	N	KR
25	90,09	N	KR
32	97,02	N	KR
35	103,95	N	KR
38	117,81	N	KR
40	138,60	N	KR
45	145,53	N	KR
50	159,39	N	KR
60	173,25	N	KR
65	190,58	N	KR
68	197,51	N	KR
73	207,90	N	KR
75	218,30	N	KR
<b>Set mały</b>	<b>537,08</b>	cięcie na mokro	
<b>Set duży</b>	<b>933,82</b>	> 50mm cięcie na sucho i mokro	



**CD 95572-Set mały**

jak powyżej zawiera odmierzenie: 6,6,6,8,8,8,10,10,12,12,14,14mm

**CD 95570-Set duży**

jak powyżej zawiera odmierzenie: 10,20,32,40,45,50,65,75mm

★★★★★

**CD 98800 Anbohrhilfe 5-30mm<sup>1)</sup>**

**CD 98910 Anbohrhilfe 4-12mm<sup>2)</sup>**

**CD 98900 Anbohrhilfe 6-82mm<sup>3)</sup>**

**CD 98600 Pompa na wodę 1-l.**



INOX	103,95	dla CD 55800, 55804, 55700, 5802, 5255	
Plastik	86,63	dla CD 55700	
Plastik	86,63	dla CD 55700	
Plastik	76,23	dla CD 98900 + 98600	

**WIERTŁA KORONOWE GRANIT, GRES, CERAMIKA CIĘCIE NA SUCHOI**

**CD 55800**

**Gres, płytki ceramiki, granit, marmur, glazura ceramiki, twarda ceramika, kamionka, płytki kamienne, terakotta, kafel, kamień, plastik itd.**

ekstremalnie szybkie i dokładne wiercenie, dla łatwiejszego ręcznego wiercenia, bardzo silne narzędzie, **bez użycia wody!** dla wystkich szlifierek kątowych, **mocowanie: M14**

6	97,02	N	KR	KL
8	100,49	N	KR	KL
10	110,88	N	KR	KL
12	121,28	N	KR	KL
14	128,21	N	KR	KL
18	138,60	N	KR	KL
20	145,53	N	KR	KL
22	159,39	N	KR	KL
25	176,72	N	KR	KL
32	194,04	N	KR	KL
35	211,37	N	KR	KL
38	228,69	N	KR	KL
40	259,88	N	KR	KL
42	270,27	N	KR	KL
45	273,74	N	KR	KL
50	308,39	N	KR	KL
55	336,11	N	KR	KL
60	363,83	N	KR	KL
65	395,01	N	KR	KL
68	412,34	N	KR	KL
75	453,92	N	KR	KL
80	481,64	N	KR	KL
82	495,50	N	KR	KL
85	512,82	N	KR	KL
90	544,01	N	KR	KL
95	575,19	N	KR	KL
100	644,49	N	KR	KL
110	727,65	N	KR	KL
120	803,88	cięcie na sucho i mokro		

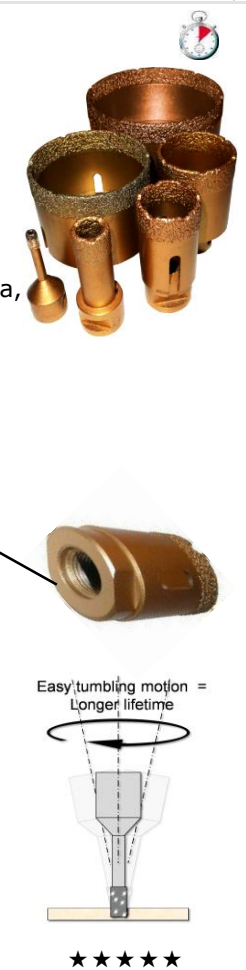

Easy tumbling motion = Longer lifetime

★★★★★







**GRES, CERAMIKA CIĘCIE NA SUCHO**

<p><b>CD 55804</b>  <b>Gres, płytki ceramiki, granit, marmur, glazura ceramiki, twarda ceramika, kamionka, płytki kamienne, terakotta, kafel...</b>                  ekstremalnie szybkie i bezproblemowe w użyciu bez prowadnicy, <b>bez użycia wody!</b></p>		5		93,56	N	KR	KL		 
		6		97,02	N	KR	KL		
		8		100,49	N	KR	KL		
		10		110,88	N	KR	KL		
		12		121,28	N	KR	KL		
		14		128,21	N	KR	KL		
		<p><b>SET CD955804 6-kt</b> 758,84  <b>SET CD955806 M14</b> 758,84</p>							
<p>★★★★★</p>						cięcie na sucho i mokro			

**WIERTŁA KORONOWE, segmentu pierścieniowe GRANIT, GRES**

<p><b>CD 5802</b>  <b>Granit, gres, kamień,</b>                  Wiertło pierścieniowe, idealna dla wszystkich twardych i bardzo twardych materiałów, <b>długość robocza: 70mm, mocowanie: 1/2" a</b></p>		6		121,28	N	KR	  
		8		131,67	N	KR	
		10		142,07	N	KR	
		12		149,00	N	KR	
		14		155,93	N	KR	
		16		169,79	N	KR	
		<p>★★★★★</p>					

<p><b>CD 5255 Diamantbohrkrone Naß</b>  <b>Gres, płytki ceramiki, płytki kamienne, terakotta</b>                  Ekstra cienki (1,5mm), szybkie, czyste cięcie, <b>ekstremalnie długa żywotność</b> dla wystkich szlifierek kątowych i wiertarek  <b>długość robocza: 32mm, mocowanie: KOMBI 1/2" a + M14i</b></p>		20	1,5	7,5	239,09	N	KR	   
		30	1,5	7,5	266,81	N	KR	
		35	1,5	7,5	280,67	N	KR	
		40	1,5	7,5	294,53	N	KR	
		45	1,5	7,5	304,92	N	KR	
		50	1,5	7,5	322,25	N	KR	
		60	1,5	7,5	401,94	N	KR	
		68	1,5	7,5	443,52	N	KR	
		70	1,5	7,5	446,99	N	KR	
		75	1,5	7,5	457,38	N	KR	
		100	1,5	7,5	589,05	N	KR	
		120	1,5	7,5	727,65	N	KR	
<p>Segment: lutowane, 7,5mm</p>						cięcie na mokro		
<p>★★★★★</p>								

<p><b>CD 99140 płukanie</b>                  wejście: <b>6-kanciasty</b>                  odejście: <b>1/2" i</b>                  dla CD 5802 + CD 5255</p>				225,23			
--	---	--	--	--------	--	--	--

**WIERTŁA KORONOWE cięcie na sucho LASER M16**

<p><b>CD 56600</b>  <b>Beton, kamień, mur ceglany, klinkier, cegła wap.-piask. twardy,</b>                  dla łatwiejszego ręcznego cięcia szybkie wiercenie, Segmenty typu "TURBO", Segmenty <b>spawane laserowo,</b></p>		30	3 segm.		103,95	B	 
		40	3 segm.		121,28	B	
		52	3 segm.		138,60	B	
		62	3 segm.		166,32	B	
		68	3 segm.		173,25	B	
		2	4 segm.		194,04	B	
		82	4 segm.		200,97	B	
		92	4 segm.		235,62	B	
		102	5 segm.		232,16	B	
		112	6 segm.		259,88	B	
		127	6 segm.		294,53	B	
		132	6 segm.		332,64	B	
		142	7 segm.		388,08	B	
		152	8 segm.		398,48	B	
		162	8 segm.		474,71	B	
182	8 segm.		509,36	B			
202	.0 segm.		592,52	B			
<p><b>CD 96600 Set</b> 1036,04</p>							
<p>1x koronowe 40, 52, 68, 82, 102mm, Adapter SDS+6kt. Kurz + lang, wiertło centrujące, <b>Alu-Trolley-Box</b></p>						Naß+Trockenschnitt	
<p>TURBO-Segment Laser 8mm</p>						★★★★★	

**WIERTŁA KORONOWE cięcie na sucho 1 1/4"****CD 56700**

Beton, kamień,  
mur ceglany, klinkier,  
cegła wap.-piask. twardy,  
dla łatwiejszego ręcznego cięcia  
szybkie wiercenie,  
Segmenty typu TURBO,  
Segmenty spawane laserowo,



68	4 sgm.	10	211,37	B						KS	
82	4 sgm.	10	273,74	B						KS	
102	5 sgm.	10	353,43	B						KS	
112	6 sgm.	10	367,29	B						KS	
127	6 sgm.	10	401,94	B						KS	
152	7 sgm.	10	440,06	B						KS	
187	9 sgm.	10	554,40	B						KS	
200	10 sgm.	10	620,24	B						KS	

długość robocza: 400mm,  
mocowanie: 1 1/4"

Segment Laser, 8mm  
★★★★

cięcie na sucho i mokro

**CD 50992 ARXX**

Freihand- und Trockenschnitt,  
Beton, KS hochverdichtet,  
Ziegel, Klinker etc.  
extrem hohe Standzeit dank  
ARXX-Segment-Technologie,  
(optimierte Diamant-Anordnung),  
Dachform, Segmenthöhe 10mm

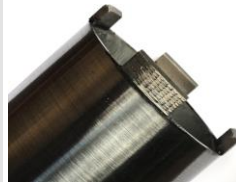

52	3 sgm.	10	294,53	B						KS	
67	3 sgm.	10	343,04	B						KS	
72	3 sgm.	10	353,43	B						KS	
82	4 sgm.	10	398,48	B						KS	
102	5 sgm.	10	516,29	B						KS	
112	5 sgm.	10	571,73	B						KS	
122	6 sgm.	10	620,24	B						KS	
127	6 sgm.	10	654,89	B						KS	
132	6 sgm.	10	675,68	B						KS	
142	7 sgm.	10	744,98	B						KS	
152	7 sgm.	10	779,63	B						KS	
162	8 sgm.	10	848,93	B						KS	
172	8 sgm.	10	1212,75	B						KS	
187	8 sgm.	10	1368,68	B						KS	
202	10 sgm.	10	1382,54	B						KS	

Aufnahme 1 1/4"  
Nutzlänge 400mm

Segment gelasert, 10mm  
★★★★

Naß+Trockenschnitt

**CD 8810 ABSAUGUNG**

für Trockenbohrkronen  
Maschinenseite: M16i  
Werkzeugseiter: 1 1/4"a



<b>Absaugung</b>	433,13	<b>CD 8810</b>	
<b>Zentrierspitze 300mm</b>		<b>CD 8812</b>	
<b>Zentrierspitze 400mm</b>		<b>CD 8814</b>	
<b>Adapter M16 / 6kt.</b>		<b>CD 8200</b>	
<b>Adapter M16 / 1/2"a</b>		<b>CD 8208</b>	
<b>Adapter M16 / 1 1/4"i</b>		<b>CD 8125</b>	

**DIAMENTOWE WIERTŁA KORONOWE 1/2"****CD 5244 LASER RING**

Beton, beton zbrojony, granit,  
mur ceglany, klinkier  
do materiałów twardych i  
średnio twardych

Wiertło pierścieniowe,  
szybkie wiercenie,  
długa żywotność,  
26 - 51mm:

Segmenty spawane laserowo,  
nie szczybienie się segmentów!

długość robocza

8-16mm: 150mm

18-51mm: 300mm

mocowanie: 1/2"a



26 - 51mm:  
spawane laserowo



wysokość segmentu: 10mm

★★★★

8	1 sgm.	10	107,42	B							
10	1 sgm.	10	110,88	B							
12	1 sgm.	10	117,81	B							
14	1 sgm.	10	121,28	B							
16	1 sgm.	10	124,74	B							
18	1 sgm.	10	131,67	B							
20	1 sgm.	10	138,60	B							
22	1 sgm.	10	142,07	B							
24	1 sgm.	10	145,53	B							
25	1 sgm.	10	149,00	B							
26	1 sgm.	10	149,00	B							
28	1 sgm.	10	159,39	B							
30	1 sgm.	10	194,04	B							
32	1 sgm.	10	204,44	B							
35	1 sgm.	10	218,30	B							
36	1 sgm.	10	218,30	B							
40	1 sgm.	10	228,69	B							
42	1 sgm.	10	252,95	B							
46	1 sgm.	10	273,74	B							
51	1 sgm.	10	318,78	B							

cięcie na mokro





**DIAMENTOWE WIERTŁA KORONOWE, spawana laserowo 1 1/4"****CD 5088 LASER TURBO**

Beton, beton zbrojony,  
mur ceglany, klinkier,  
materiałów twardych i  
średnio twardych

Bardzo uniwersalny  
szybkie wiercenie,  
długa żywotność  
Segmenty typu "TURBO",  
Segmenty **spawane laserowo**,  
nie szczyrbienie się segmentów!

Idealny dla instalatorów.

długość robocza: 400mm,  
mocowanie: 1 1/4"i

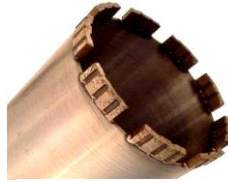

Segment Laser, 10mm

★★★★★

**spawane laserowo**

32	4sgm.	10	149,00	B					
42	4sgm.	10	159,39	B					
52	5sgm.	10	169,79	B					
58	5sgm.	10	204,44	B					
63	6sgm.	10	225,23	B					
65	6sgm.	10	225,23	B					
68	6sgm.	10	235,62	B					
70	6sgm.	10	259,88	B					
82	7sgm.	10	284,13	B					
92	8sgm.	10	336,11	B					
102	8sgm.	10	360,36	B					
108	8sgm.	10	388,08	B					
112	9sgm.	10	405,41	B					
122	10sgm.	10	419,27	B					
127	10sgm.	10	443,52	B					
132	11sgm.	10	467,78	B					
152	12sgm.	10	540,54	B					
162	12sgm.	10	571,73	B					
165	12sgm.	10	620,24	B					
172	12sgm.	10	658,35	B					
182	13sgm.	10	686,07	B					
202	15sgm.	10	727,65	B					
250	17sgm.	10	1022,18	B	cięcie na sucho i mokro				

**CD 5077 PREMIUM LASER-DACH 1 1/4"**

Beton, beton zbrojony,  
materiałów twardych,  
universal,  
segment typu „DACH”, 10mm,  
**ekstremalnie długa  
żywołność**

Laser  
SUPER-PREMIUM

długość robocza: 400mm,  
mocowanie: 1 1/4"i









Segment Laser, 10mm

★★★★★

52	5sgm.	10	235,62	B					
63	6sgm.	10	277,20	B					
68	6sgm.	10	308,39	B					
72	6sgm.	10	325,71	B					
82	8sgm.	10	395,01	B					
92	8sgm.	10	446,99	B					
102	9sgm.	10	485,10	B					
112	10sgm.	10	540,54	B					
122	10sgm.	10	571,73	B					
132	11sgm.	10	620,24	B					
152	12sgm.	10	717,26	B					
162	13sgm.	10	765,77	B					
182	14sgm.	10	862,79	B					
200	15sgm.	10	1105,34	B	cięcie na sucho i mokro				



**AKCESORIA**

11/4"a+1/2"i x HILTI DDBU <sup>1)</sup>		<b>CD 5600GR</b>	für DD160, 250, 400, 750HY	
11/4"a+1/2"i x HILTI DDBI <sup>2)</sup>		<b>CD 5602</b>	für DD100, 120, 130	
11/4"a x HILTI DDBL NEU <sup>3)</sup>		<b>CD 5601</b>		
11/4"a x Würth i		<b>CD 8196</b>		
11/4"i x Würth a		<b>CD 8197</b>		
1/2"i x Würth i		<b>CD 8185</b>		
1/2"i x SDS-plus		<b>CD 8128</b>		
11/4"a + 1/2"i x M18x2,5i		<b>CD 8120</b>		
11/4"a + 1/2"i x M18x2,5i		<b>CD 8120</b>		
11/4"i x M16a		<b>CD 8125</b>		
11/4"a x M16i		<b>CD 8126</b>		
1/2"i x 1/2"i		<b>CD 8102</b>		
1/2"i x 6-kt.		<b>CD 8124</b>		
11/4"i x 1/2"i		<b>CD 8100</b>		
11/4"i x 1/2"a		<b>CD 8127</b>		
11/4"a x 1/2"i		<b>CD 8110</b>		
11/4"a x 1/2"a		<b>CD 8105</b>		
3-Loch x 11/4"i+Schrauben		<b>CD 8195</b>		
3-Loch x 11/4"a		<b>CD 8190</b>		
6-Loch x 11/4"i+Schrauben	<b>CD 8193</b>			
4-Loch x 11/4"i	<b>CD 8194</b>			
4-Loch x 11/4"a				
3-Loch x 1/2"a		<b>CD 8192</b>		
5/8"i x M18x2,5a		<b>CD 8222</b>		
5/8"a x 1/2"a		<b>CD 8226</b>		
5/8"i x 1/2"i		<b>CD 8154</b>		
M14a x 1/2"a		<b>CD 8156</b>	zu Einsatz v. CD 55800 auf Spülkopf	
M14a x 6-kt (10mm)		<b>CD 8156</b>	zu Einsatz v.CD 55800 in Bohrmaschine	
M14a x 6mm Rundschaft (f. Bosch Fliesenbohrmaschine)		<b>CD 8153</b>	zu Einsatz v.CD 55800 in Bohrmaschine	
M14a x SDS-plus		<b>CD 8157</b>	zu Einsatz v. CD 55800 in Bohrhammer	
Zentrierstange 450mm 1/2"a für Maschinen mit 1/2"i				
Leichtlösering für 11/4"-Bohrkronen		<b>SLIDER</b>		
CU-Ringe für 11/4"-Bohrkronen 38 x 32 x 1,8 mm		<b>CD 99130</b>		

<b>CD 8000</b>		...100			
Przedłużenie stal 1/2" x ...mm		...200			
		...300			
		...400			
		...500			

<b>CD 8010</b>		...100			
Przedłużenie stal 11/4" x ...mm		...200			
		...300			
		...400			
		...500			

**KORZENIE, GUMA**

<b>CD 0350 WURZELSCHNEIDER</b>		125				
Wurzelholz im Erdbereich,		230				
Bauholz, Paletten, Gummi,		300				
Dachpappe etc. etc., durch		350				
extra grobe HM-Bestückung kein Zusetzen,		400				
kein Abstumpfen im Sand,						
besonders Stabiles Stammblatt						
	<i>für Winkelschleifer und Motorsägen</i>					